

MANUAL – INSTALLATION

Ultrasuite Array

Operating Room Diffuser System with LED Lighting

v200 – Issue Date: 08/30/23

© 2023 Price Industries Limited. All rights reserved.

PRICE[®]

ULTRASUITE ARRAY

TABLE OF CONTENTS

Product Overview

Details.....	1
--------------	---

Installation Instructions

Pre-Installation Instructions and Checklist.....	2
Luminaire Mounting and Installation.....	3

ULTRASUITE ARRAY

PRODUCT OVERVIEW

Details

The Price Ultrasuite Assembly (USA) luminaire will be an array of module assemblies.

MODULE ARRAY ▼

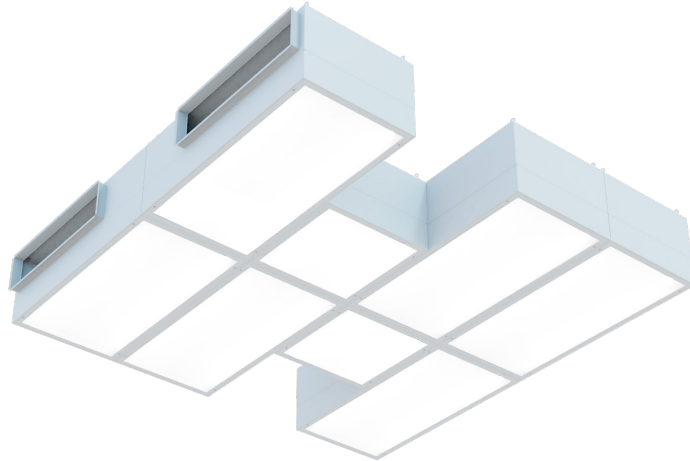

The luminaire is identified with a model code of USA-XX, where XX is the approximate footprint area (square feet) of the luminaire. The identification label for a luminaire with a footprint area of 4 square feet is shown.

LABEL USA-04 ▼

price [®] 269822-001	
MODEL USA-04	SERIAL 1234567-000-000
SUITABLE FOR AIR HANDLING USE/CONVIENT AU TRAITEMENT DE L'AIR	
TYPE IC / TYPE IC	INHERENTLY PROTECTED/ PROTECTION INÉHRENTE
SUITABLE FOR DRY AND DAMP LOCATIONS/CONVIENT AUX ENDROITS SECS ET HUMIDES	
ACCESS ABOVE CEILING REQUIRED / ACCÈS REQUIS AU-DESSUS DU PLAFOND	
RELAMP WITH/UTILISER UNE AMPOULE DE REPLACEMENT DE: LED LINEAR VARIOLED HYDRA HD25 W827-W835 IP67	
ASSEMBLE PART USA ONLY WITH URDC /ASSEMBLER LA PIÈCE USA SEULEMENT AVEC LA PIÈCE URDC	

The luminaire will come with a remote LED driver cabinet with pre-wired driver connections. The quantity of the drivers varies with the size of the luminaire system. The below images show the two types of driver cabinet options available. Please refer to URDC installation manual for more information.

ULTRASUITE ARRAY

INSTALLATION INSTRUCTIONS

Pre-Installation Instructions and Checklist

Read and Save These Instructions

Warning

- To reduce the risk of fire, electrical shock, or injury to persons, observe the following:
 - Installation work and electrical wiring must be done by a qualified person(s) in accordance with all applicable codes and standards, including fire-rated construction.
 - Unit must be used in supply applications only, and access above the ceiling is required.

Before you start

- Inspect all cartons and boxes for flaws and shipping damage.
 - If anything is found to be damaged, contact the shipping company and file a freight claim.
- Review Price project specific submittals to ensure booms are located in the correct locations (recommended to measure and chalk outline of ceiling system on floor).
- If drywall perimeter is installed prior to the system, ensure that the opening is cut to the correct dimensions (as per the submittal), and is square on all corners.
- Ensure all tools (as listed below) are on site and ready for use.
- A minimum of two (2) people will be required to install this system.

Required Tools/Parts

- To be supplied by contractor.
 - (2+) 8 ft. ladders or scaffolding
 - Laser level
 - Cordless drill/impact
 - #8 self-tapping screws (1/2 in. maximum length)
 - Screwdriver bit(s) to suit self-tapping screws
 - Allen keys (5/32 in. and 3/16 in.)
 - Damp cloth(s) (for cleaning)
 - Utility knife
 - Chalk line
 - Pliers with wire cutter
 - Tape measure
 - Clamps/locking plier
 - Pre-stressed 12 gauge suspension wire (or approved alternative) with necessary equipment to hang wire
- Supplied by Price:
 - Job specific submittal drawing showing all sizes and dimensions of module assembly sections
 - Luminaire module sub-assembly sections (refer to job submittal drawing for quantity and sizes)
 - Remote driver cabinets (refer to job specific submittal drawing for quantity, sizes and field wiring connection details)
 - Dimmer switches (refer to job specific submittal drawing for quantity and field wiring connections)
 - HGWC Perimeter ceiling sections (if applicable)
 - 1/32 in. x 3/4 in. (t x w) white gasket tape – for between modules (Part Number 042373 004)
 - The following supplied for bolting module assemblies together:
 - Bolt
 - Metal washer
 - Lock nut

ULTRASUITE ARRAY

INSTALLATION INSTRUCTIONS

Luminaire Mounting and Installation

Step 1: Snap chalk line on the floor to outline locations and sizes of module assembly sections.

Step 2: Unpack module assembly sections and lay them out on the floor as per the job specific submittal package and determine remote driver cabinet mounting location. Ensure adequate wire length is available to wire to the remote cabinet. Refer to the [URDC Installation manual](#) for the cabinet mounting and installation, electrical connections and wiring diagrams.

NOTE: Ensure floor surface is clean and free of debris that could damage the product finish.

NOTE: Ensure that adjacent module assembly sections have mated inlets in the correct locations.

ENSURE MATED INLETS ARE ALIGNED CORRECTLY ▼

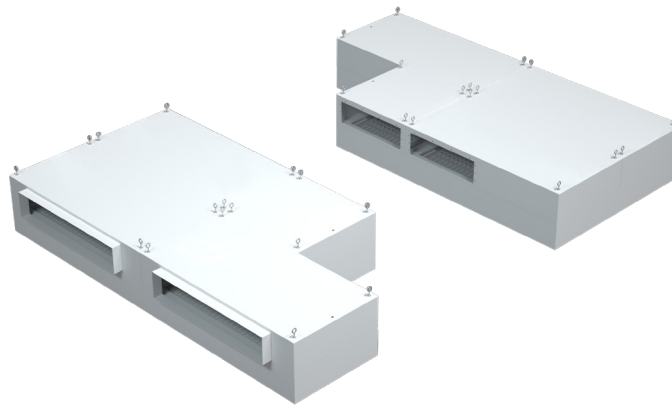

Step 3: Attach lengths of pre-stressed 12 gauge suspension wire to the slab or structural steel above the ceiling according to ASTM C636, and any applicable local codes, ensuring that a minimum of four (4) suspensions points are used per module.

SUSPENSION WIRE ATTACHED TO STRUCTURE ▼

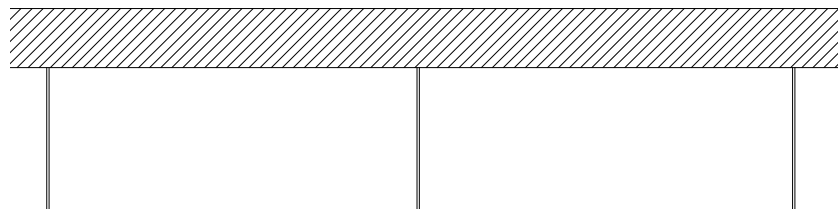

NOTE: Ensure that the perimeter drywall (if installed) and other equipment are installed at the correct heights using a laser level.

Step 4: Extend hanger wires 6 in. below the top of the plenum (refer to job specific submittal for plenum height) and snip to length as required.

ULTRASUITE ARRAY

INSTALLATION INSTRUCTIONS

Step 5: Remove the polycarbonate diffuser face by disengaging the flat head drive quarter turn fastener.

POLYCARBONATE DIFFUSER FACE REMOVAL ▼



Step 6: Using a 3/16 in. Allen key, unscrew the damper mounting screw to release the aperture plate damper for access to the plenum.

LOOSEN DAMPER MOUNTING SCREW ▼

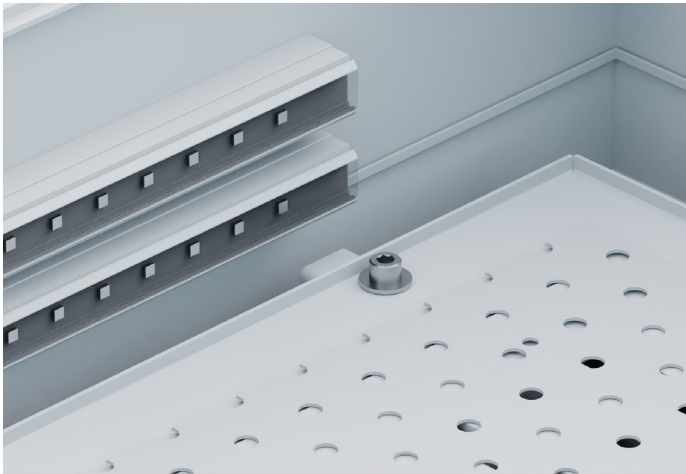

REMOVE DAMPER MOUNTING SCREW ▼



APERTURE PLATE DAMPER REMOVAL ▼

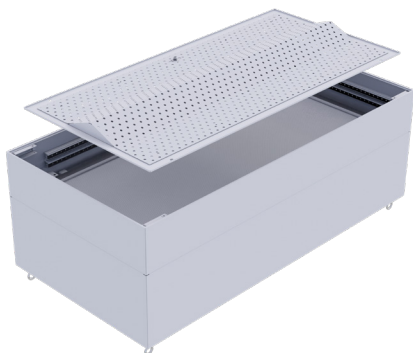

OPEN PLENUM (DAMPER REMOVED) ▼

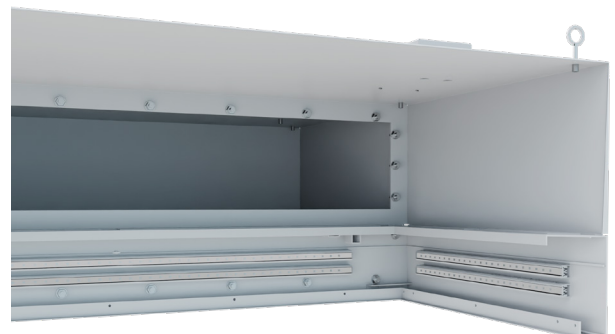

ULTRASUITE ARRAY

INSTALLATION INSTRUCTIONS

Step 7: Raise the first module assembly, temporarily supporting it using hanger wire. Do not twist the wires at this stage; bend in loose, 180° loops allowing leveling of the system once all modules are in place.

TEMPORARY HANGER SUPPORT ▼

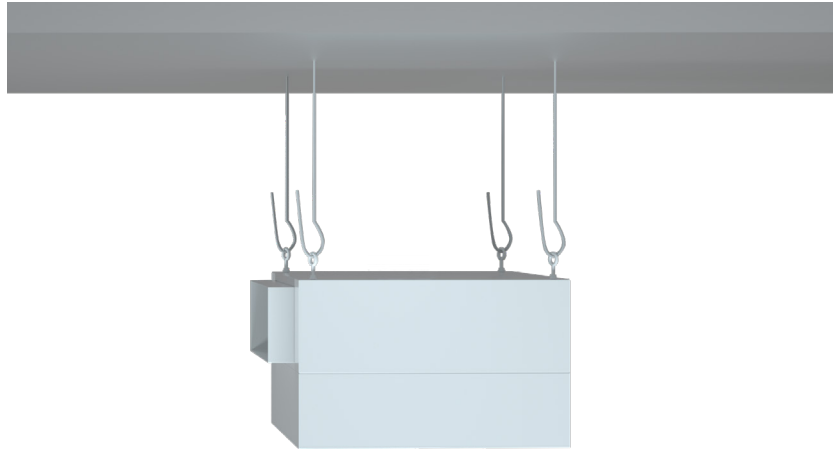

Step 8: Raise adjacent module assemblies, temporarily supporting the modules with hanger wire. Fasten modules together using bolts, metal washers, and lock nuts supplied by Price. Module sections will have slotted holes for fastening. Bottom of modules should be flush and level prior to fastening together.

HARDWARE ▼

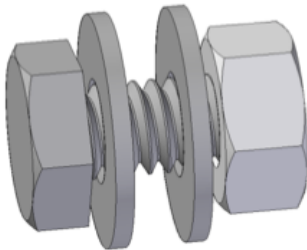

SECTION VIEW OF MODULES BOLTED TOGETHER ▼

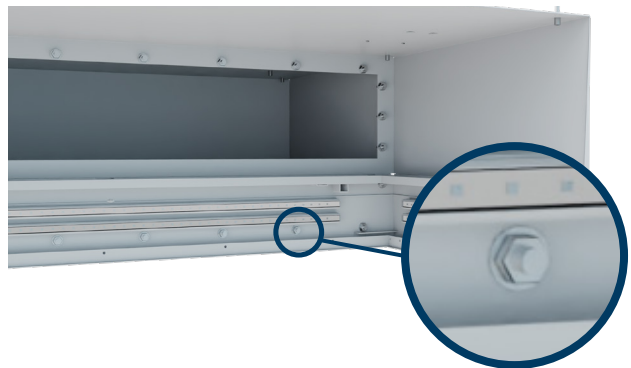

MODULE SECTION CLOSE-UP ▼

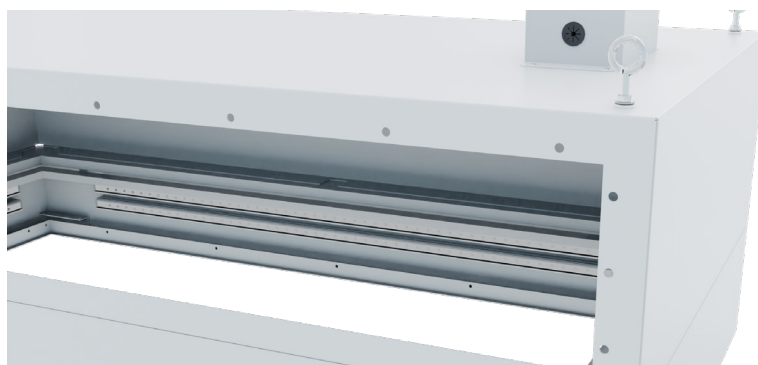

ULTRASUITE ARRAY

INSTALLATION INSTRUCTIONS

Step 9: Repeat step 8 until all sections are installed.

Step 10: Apply adhesive sealant at the locations shown below, for connections done on-site.

VERTICAL AND TOP HORIZONTAL SEAMS AT THE MODULE SECTION CONNECTIONS DONE ON-SITE ▼

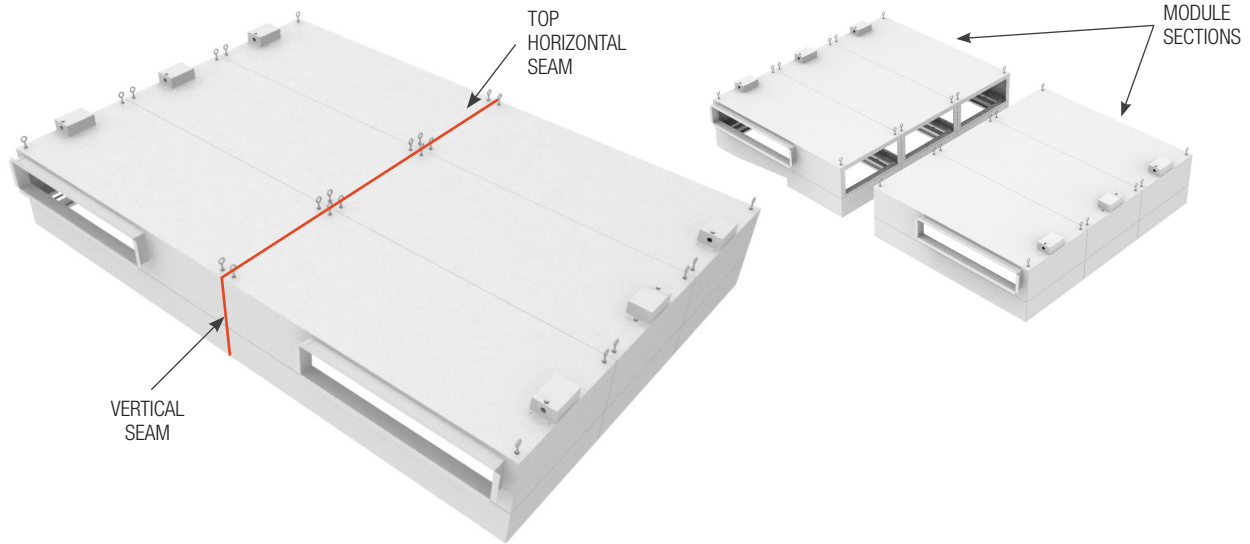

ROOM-SIDE SEAMS AT THE MODULE SECTION CONNECTIONS DONE ON-SITE ▼

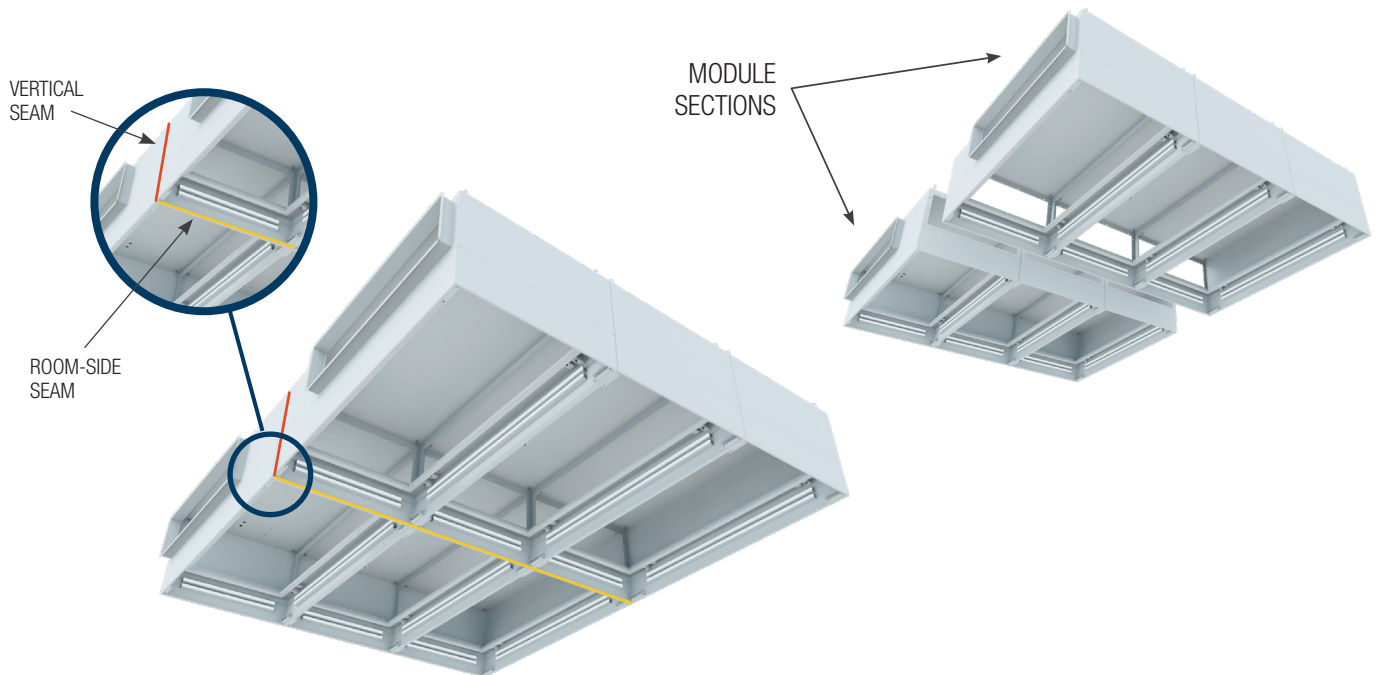

NOTE: Wipe off excessive sealant and allow it to dry before installing the faces

ULTRASUITE ARRAY

INSTALLATION INSTRUCTIONS

PLENUM OPENING SEAMS AT THE MODULE SECTION CONNECTIONS DONE ON-SITE ▼

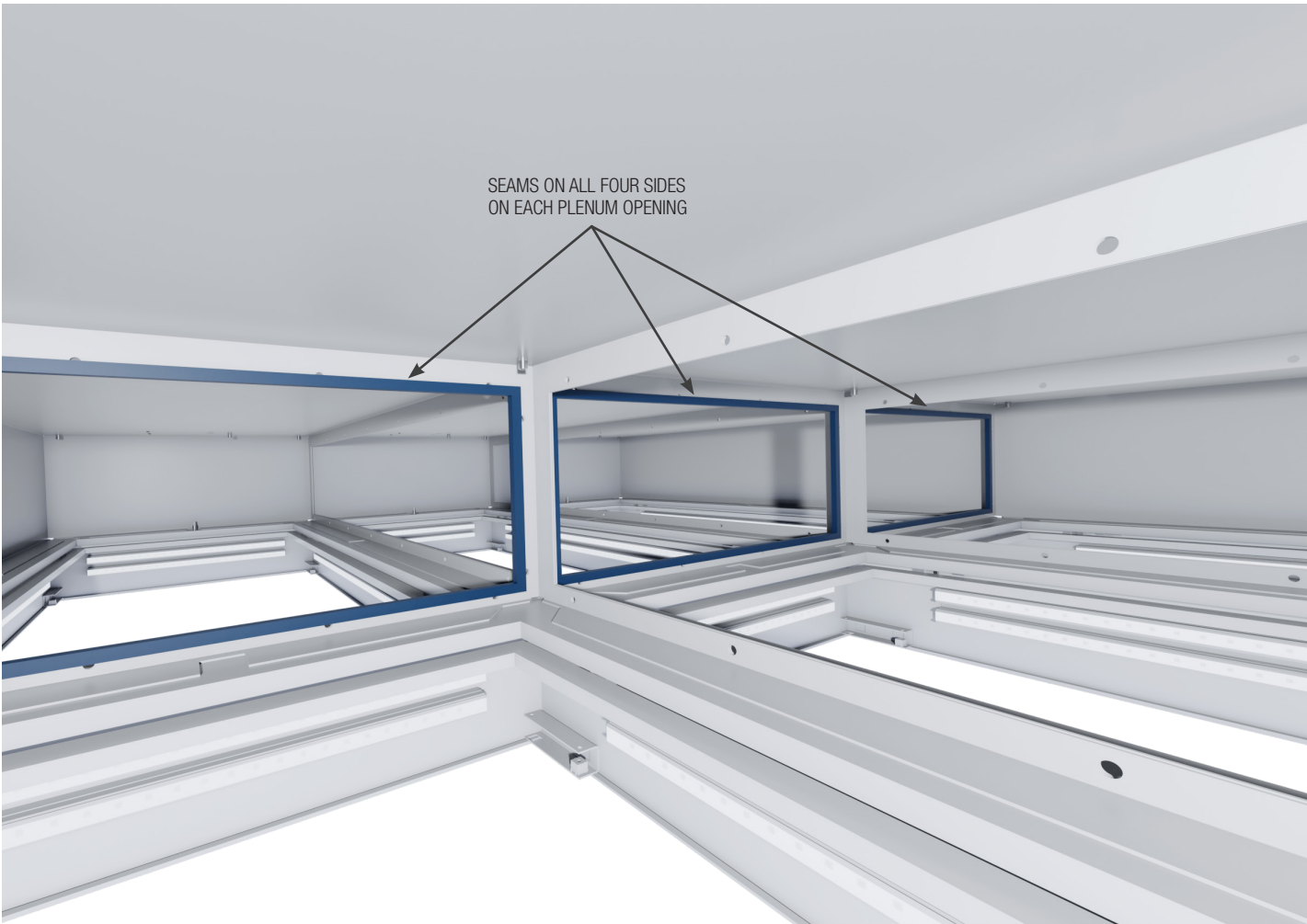

ULTRASUITE ARRAY

INSTALLATION INSTRUCTIONS

Step 11: Pull down the perimeter modules to tension the wires, and adjust the wire to minimize settling and moving of the plenum assembly once the damper and face are installed. Ensure that modules are tight to the adjacent ceiling system or drywall (if installed/applicable), and/or at the correct height and that there is no slack in the hanger wires.

NOTE: Perimeter drywall must be installed slightly above the height of the rest of the ceiling, as it needs to rest on the backside of the perimeter tee.

Step 12: Tighten hanger wire by twisting and securing per ASTM C636 and/or applicable local codes.

Step 13 (Filtered Option Only): Remove new filter from packaging. Only handle filters by the aluminum frame, as any contact with filter media will damage the filter and impact filter effectiveness. Install filter gel seal on plenum knife-edge and secure in place using the four corner tabs. Tighten tabs with Allen key

NOTE: Two people are recommended for filter installation.

Step 14: Re-install damper assembly and tighten the damper mounting screws.

REPLACE DAMPER APERTURE PLATE ▼



TIGHTEN DAMPER MOUNTING SCREW ▼



Step 15: Connect ductwork and balance the Ultrasuite system inlet accordingly.

NOTE: If minor airflow adjustments are required, adjust damper by loosening and sliding the screw with a 3/16 in. Allen key.

DAMPER APERTURE PLATE ADJUSTMENT ▼

SLIDE DAMPER APERTURE PLATE FOR AIRFLOW ADJUSTMENT BY LOOSENING AND SLIDING THE SCREW WITH A 3/16 IN. ALLEN KEY.

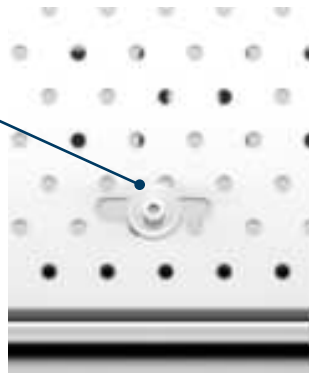

CLOSED
FULL LEFT OR FULL RIGHT POSITION



OPEN
CENTER POSITION



ULTRASUITE ARRAY

INSTALLATION INSTRUCTIONS

Step 16: Re-install face and secure in place by tightening countersunk screws. Do not fully tighten the countersunk screws until all faces in the array have been installed and aligned.

Step 17: If perimeter welded ceiling grid (HGWC) is being used; apply gasket (Part Number 042373-004) to one outside (vertical) surface of the half tee where two modules meet. The gasket is supplied in 50ft rolls – measure and cut the gasket as required.

GASKET INSTALLATION CROSS SECTION ▼

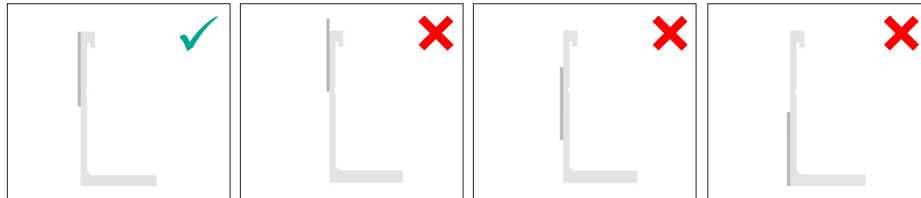

NOTE: Gasket should be installed as close to the top of the tee as possible – do not extend past the top of the tee. Ensure that only one half tee has the gasket applied. Do not stretch gasket as it is being applied, as this will cause it to pull away from the tee over time.

Step 18: Screw half tees to the perimeter Ultrasuite module.

PERIMETER HALF TEE INTEGRATION ▼

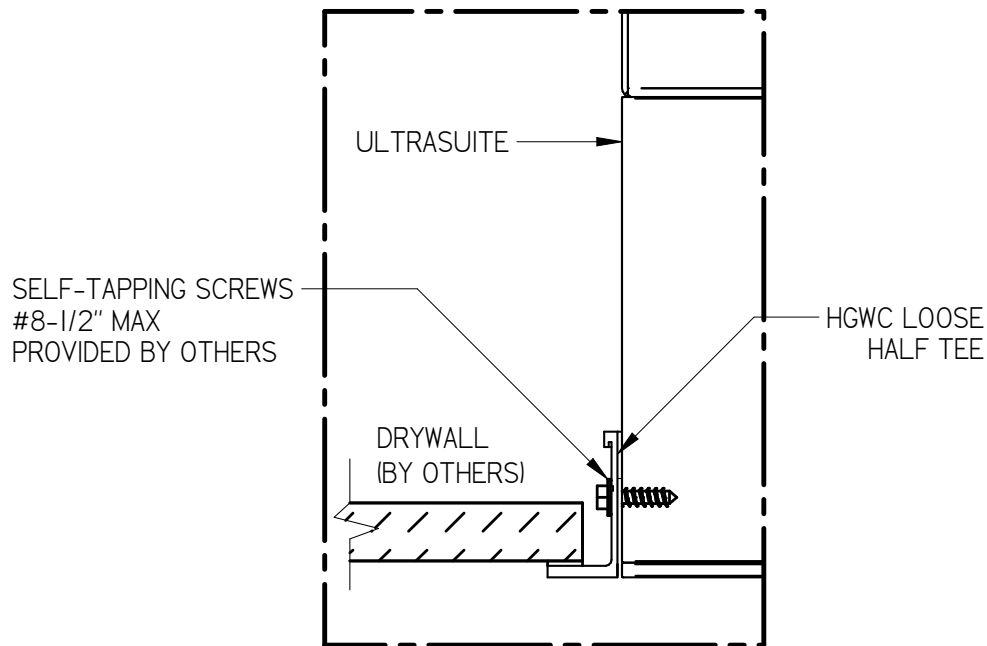

Step 19: Refer to [HGWC Installation manual](#) (if applicable) for the remainder of the Hospital Grade Welded Ceiling (HGWC) system.

Step 20: Refer to the [URDC Installation manual](#) for instructions on installation and wiring of the Ultrasuite modules.

This document contains the most current product information as of this printing.
For the most up-to-date product information, please go to priceindustries.com

© 2023 Price Industries Limited. All rights reserved.

